

Date: \_\_\_\_\_

Client: \_\_\_\_\_

Project: \_\_\_\_\_

VOLA product: 311



**311**

One-handle build-in mixer with ceramic disc technology. 311UP = Mixer 300. 311AP = Handle NR28, 160 mm fixed spout 010, 60 mm circular flanges 001, 3001.

Ada approved.

**Flow**

	Bar:	1.0	2.0	3.0	4.0	5.0
311	(l/min)	2.9	4.1	5.0	5.0	5.0
311 <sup>1)</sup>	(l/min)	2.6	3.7	4.5	4.5	4.5

<sup>1)</sup> USA Standard

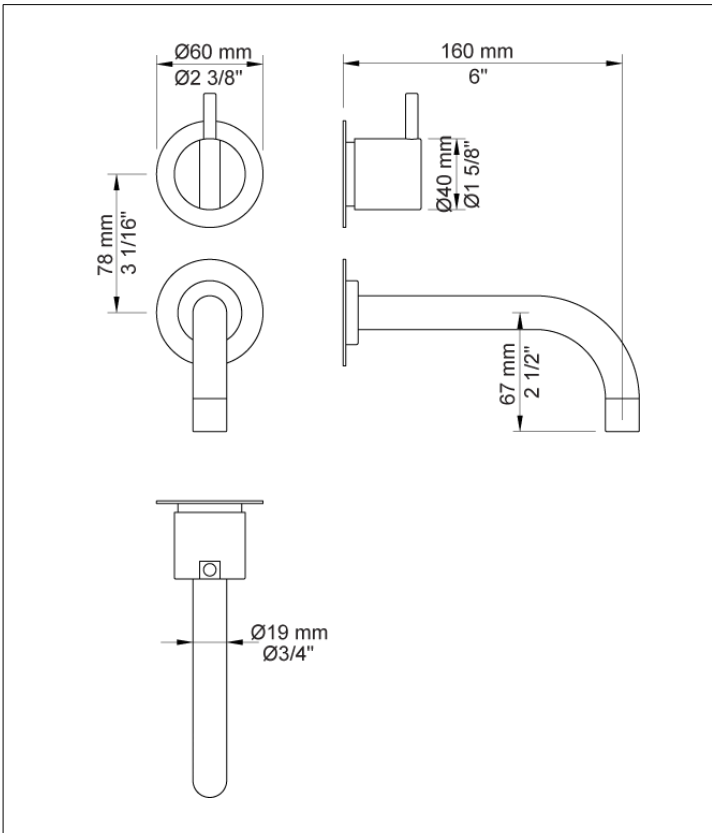

**Available in colors**

- Color 02, Grey
- Color 04, Light blue
- Color 05, Orange
- Color 06, Light green
- Color 08, Yellow
- Color 09, Dark grey
- Color 12, Mocca
- Color 14, Bright red
- Color 15, Dark blue
- Color 16, Polished chrome
- Color 17, Gloss black
- Color 18, White
- Color 19, Natural brass
- Color 20, Brushed chrome
- Color 21, Carmine red
- Color 25, Pink
- Color 27, Matt black
- Color 40, Brushed stainless steel



Date:

Client:

Project:

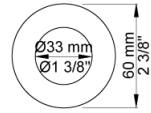
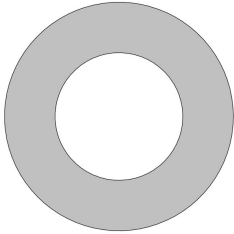

**001**  
60 mm circular flange. Hole Ø33 mm.

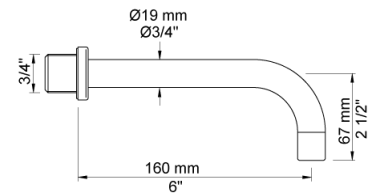

**010**  
160 mm fixed spout with water saving aerator.

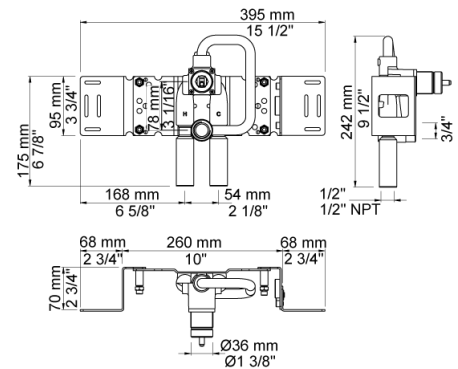
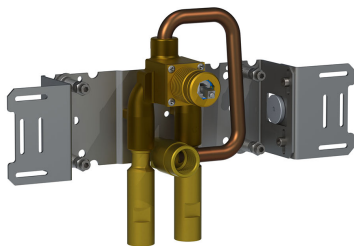

**300**  
One-handle build-in mixer with fixed outlet socket, for vertical installation. 1/2" connection to copper, steel, iron or pex pipe work.

Date:

Client:

Project:

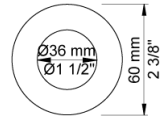

**3001**  
60 mm circular flange. Hole Ø36 mm.

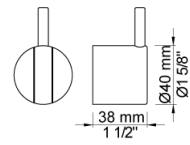

**NR28**  
Operating handle for 100, 200, 300, 400 incl. variants. Ø40 mm.