

Date:

Client:

Project:

VOLA product: 1513K



**1513K**

Two-handle build-in mixer with ¼ turn ceramic disc technology. 1513KUP = Mixer 1500. 1513KAP = 2 pcs. handles NR17, 160 mm fixed spout 010, three-hole plate 60 x 230 mm 003K.

**Flow**

	Bar:	1.0	2.0	3.0	4.0	5.0
1513K	(l/min)	2.9	4.1	5.0	5.0	5.0
010 <sup>1)</sup>	(l/min)	2.6	3.7	4.5	4.5	4.5

<sup>1)</sup> USA standard

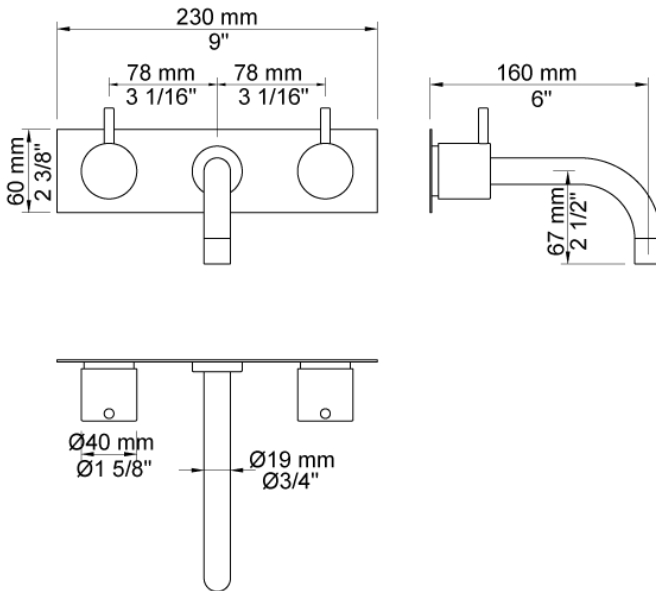

**Available in colors**

- Color 02, Grey
- Color 04, Light blue
- Color 05, Orange
- Color 06, Light green
- Color 08, Yellow
- Color 09, Dark grey
- Color 12, Mocca
- Color 14, Bright red
- Color 15, Dark blue
- Color 16, Polished chrome
- Color 17, Gloss black
- Color 18, White
- Color 19, Natural brass
- Color 20, Brushed chrome
- Color 21, Carmine red
- Color 25, Pink
- Color 27, Matt black
- Color 40, Brushed stainless steel



Date:

Client:

Project:



**003K**  
Three-hole plate, 60 x 230 mm. Holes Ø33 mm.

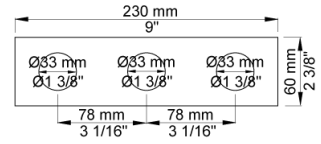

**010**  
160 mm fixed spout with water saving aerator.

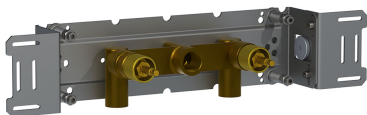
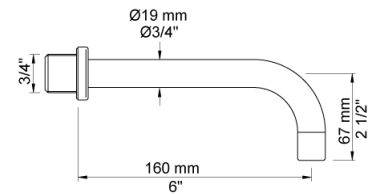

**1500**  
Two-handle build-in mixer with fixed outlet socket in the middle. 1/2" connection to copper, steel, iron or pex pipe work.

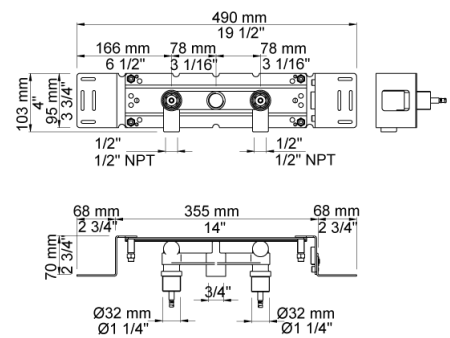

Date:

Client:

Project:

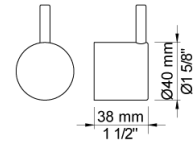

**NR17**

Operating handle for 600, 700, 800, 900, 1500, 2800, 2900, S20, S21, S40, S42 incl. variants. Ø40 mm.